

Nephelometric system for the automatic and continuous measurement of low level turbidity in pure and ultra pure water

Monitor AMI Turbitrace

- High precision nephelometer complying with ISO 7027 (EN 27027, DIN 38404)
- Measurement range: 0.000 - 100.0 FNU/NTU Automatic range switching.
- Precision: ± 0.001 FNU/NTU or $\pm 1\%$ of reading.
- Response time: typically $T_{90} < 15$ sec (after sample entry at 10 l/h)
- Programmable automatic zero point measurement for drift compensation by integrated sub-micron particle filter.
- Complete system including transmitter, turbidity sensor, flow cell with integrated sub-micron filter, flow controller and flow sensor. Installed on panel for immediate use.
- Valve and connector for slope calibration with formazine according to ISO 7027.
- Pressure tight sample system up to 10 bar avoids outgassing of sample.
- Transmitter with large backlit graphic display for the reading of measuring value, flow and operating status. Full text menu driven user interface. Storage of calibration history.
- Two signal outputs for measuring values or as control outputs.
- Alarm contact as summary alarm indication for programmable alarm values and for instrument faults. Alarm functions include: "Flow out of range", "Cleaning required" and "Replace filter".
- Two potential-free contacts programmable as limit switches or PID-controllers.
- Input for potential-free contact with programmable function.

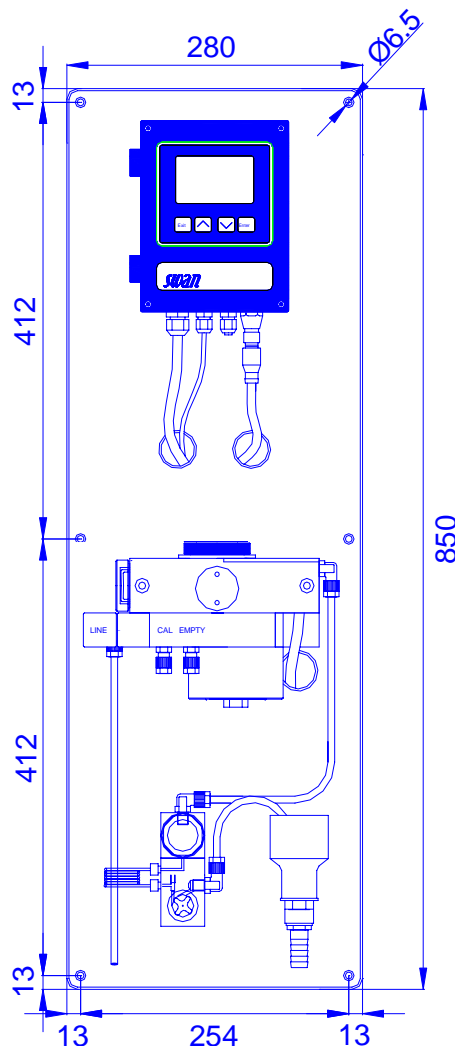

Order scheme	Monitor AMI Turbitrace	A	2	5	4	1	.	5		0
Power supply:	100 - 240 VAC, 50/60 Hz			1						
	24 VDC, direct current			2						
Interface option:	None									0
	Interface PROFIBUS DP									2
	Interface HyperTerminal (for data logger download)									3
	Interface Modbus (for Webserver connection)									4

Turbidity Measurement

Turbidimeter with flow controller and programmable automatic zero point measurement for drift compensation by integrated sub-micron particle filter.

Measurement range:
0.000 - 100.0 FNU/NTU with automatic range switching

Precision:
±0.001 FNU/NTU or ±1% of reading

Transmitter Specifications and Functionality

Electronics case: Cast aluminum
Protection degree: IP 66 / NEMA 4X
Display: backlit LCD, 75 x 45 mm
Electrical connectors: screw clamps
Dimensions: 180 x 140 x 70 mm
Weight: 1.5 kg
Ambient temperature: -10 to +50 °C
Humidity: 10 - 90% rel., non condensing

Power supply

Voltage: 100 - 240 VAC (± 10 %),
50/60 Hz (± 5 %)
or 24 VDC (± 15 %)
Power consumption: max. 20 VA

Operation

Easy operation based on separate menus for "Messages", "Diagnostics", "Maintenance", "Operation" and "Installation".

User menus in English, German, French and Spanish.

Separate menu specific password protection.

Display of process value, sample flow, alarm status and time during operation.

Storage of event log, alarm log and calibration history.

Storage of the last 1'500 data records in logger with selectable time interval.

Safety features

No data loss after power failure, all data is saved in non-volatile memory.

Over-voltage protection of in- and outputs.

Galvanic separation of measuring inputs and signal outputs.

Transmitter temperature monitoring with programmable high/low alarm limits.

1 Alarm relay

One potential free contact for summary alarm indication for programmable alarm values and instrument faults.

Maximum load: 1A / 250 VAC

1 Input

One input for potential-free contact. Programmable hold or remote off function.

Electrical Connection Scheme

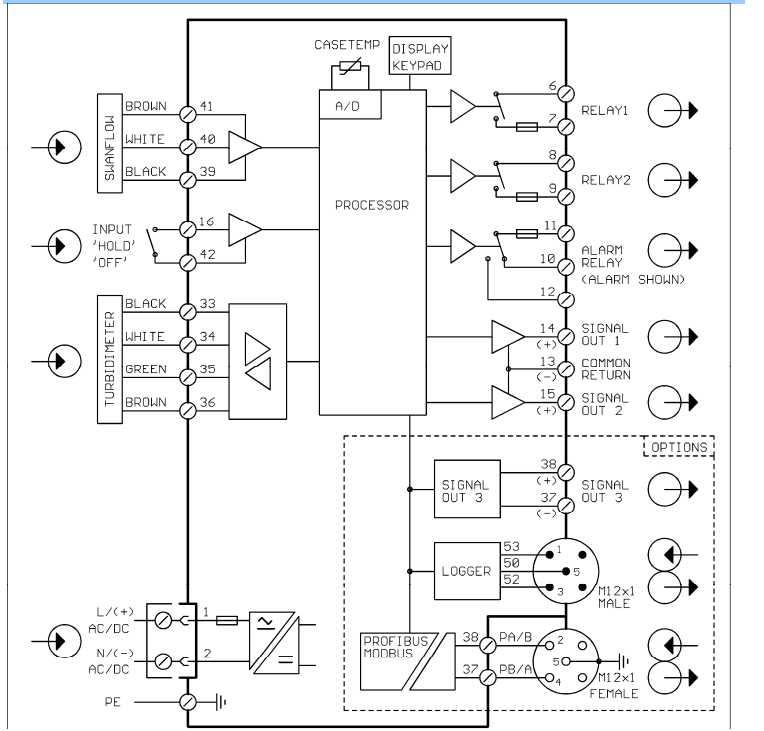

2 Relay outputs

Two potential-free contacts programmable as limit switches for measuring values, controllers or timer for system cleaning with automatic hold function.
Rated load: 1A / 250 VAC

2 Signal outputs

Two programmable signal outputs for measured values (freely scaleable, linear or bilinear) or as continuous control output (control parameters programmable).
Current loop: 0/4 - 20 mA
Maximum burden: 510 Ω

Control functions

Relays or current outputs programmable for 1 or 2 pulse dosing pumps, solenoid valves or for one motor valve. Programmable P, PI, PID or PD control parameters.

1 Communication interface (option)

RS232 interface for logger download to PC with Microsoft HyperTerminal or RS485 interface (galvanically separated) with Fieldbus protocol Modbus or Profibus DP.

Monitor Data

Sample conditions

Sample temperature: 1 - 40 °C
Sample flow: 5 - 20 l/h
Sample pressure: 1 - 10 bar

Sample connections

Sample inlet: Serto connection for tube 6 mm
Sample outlet: Pressure free outlet (funnel with connection for flexible tube 15 x 20 mm)

Panel

Panel dimensions: 850 x 280 x 200 mm
Panel material: PVC
Total monitor weight: 8.7 kg