

Analyzer for the continuous determination of dissolved sodium in the ppb-range for steam, condensate and high purity water for samples with pH ≥ 7.

**Analyzer AMI Sodium P**

Complete system mounted on stainless steel mounting panel.

- **Transmitter AMI Sodium P** in a rugged aluminum enclosure (IP66)
- **Flow cell** with temperature probe, sodium sensor, reference, pH sensor and bubble detector.
- Reliable alkalization reagent addition with continuous pH monitoring.
- Continuous sample flow detection.
- Simple two-point calibration.
- Easy to use grab sample capability.
- Factory tested, ready for installation and operation.

**Specification**

- Measuring range: 0.1 – 10'000 ppb Na (under reference conditions) with automatic range switching.
- Automatic temperature compensation.
- Big backlit LC display for the reading of all measured values and status information simultaneously.
- Easy user menus in English, German, French and Spanish. Simple programming of all parameters by keypad.
- Electronic record of major process events and calibration data.
- Real-time clock for time stamp in data logs and for automated functions.

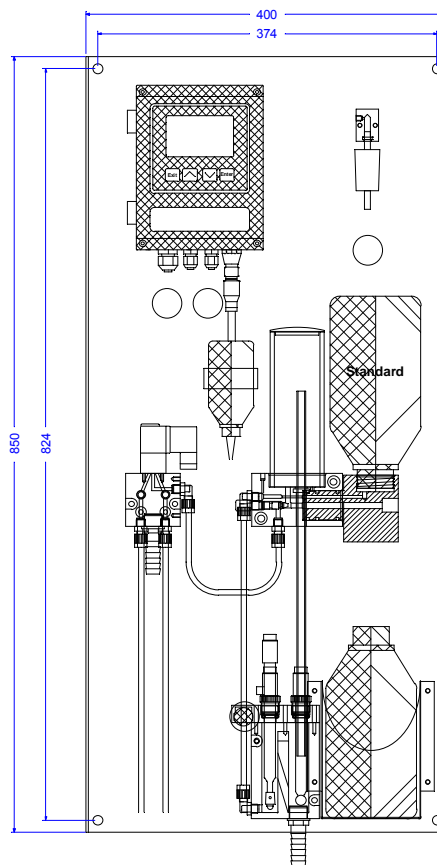

Analyzer with optional 2<sup>nd</sup> sample stream

- Data logger for 1'500 data records stored at selectable intervals. (Data download to PC requires optional HyperTerminal interface).
- Option for second sample stream with programmable stream switching.

Order scheme	Analyzer AMI Sodium P	A	2	4	4	X	X	.	X	X	0
<b>Mounting panel</b> .....	Panel width 280 mm .....					1					
	Panel width 400 mm (required for 2 sample streams!) .....					2					
<b>Power supply</b> .....	100 – 240 VAC / 50/60 Hz .....						1				
	24 VDC, direct current .....						2				
<b>Number of sample streams</b> ....	One sample stream .....								1		
	Two sample streams with stream switching valve (panel width 400 mm!)..								2		
<b>Electrical output option</b> .....	None .....										0
	Third current signal output 0/4 - 20 mA .....										1
	Profibus DP interface .....										2
	HyperTerminal interface (for logger download) .....										3
	Modbus interface (for Webservice connection).....										4

## Sodium Measurement

Sodium electrode, calomel reference electrode (liquid junction: ground glass sleeve) and pH electrode.

pH-conditioning with diisopropylamine (~1 L / 30 d) or ammonia (~3 L / 30 d).  
Interferences: none, if total acidity of sample < 10 meq/l

Automatic temperature compensation.

<b>Measuring range</b>	<b>Resolution</b>
0 - 99.9 ppb	0.1 ppb
0 - 999 ppb	1 ppb
0 - 9.99 ppm	0.01 ppm

Automatic range switching.  
Accuracy: ± 5% of reading after calibration  
Repeatability: 5%  
Response time: 180 s (95%)

**Sodium calibration**  
Manual 1- or 2-point calibration with direct standard injection.

**Temperature measurement**  
Temperature sensor SWAN NT5K  
Measuring range: -10 to +100 °C  
Resolution: 0.1 °C

## Transmitter Specifications and Functionality

Electronic case: Aluminum  
Protection degree: IP 66 / NEMA 4X  
Display: backlit LCD, 75 x 45 mm  
Electrical connectors: screw clamps  
Dimensions: 180 x 140 x 70 mm  
Weight: 1.5kg  
Ambient temperature: -10 to +50 °C  
Humidity: 10 - 90 % relative non condensing

**Power supply**  
Voltage: 100 - 240 VAC (± 10 %), 50/60 Hz (± 5 %) or 24 VDC (± 15 %)  
Power consumption: max. 20 VA

**Operation**  
Easy operation based on separate menus for "Messages", "Diagnostics", "Maintenance", "Operation" and "Installation".  
User menus in English, German, French and Spanish.  
Separate menu specific password protection.

Display of process values, alarm status and time during operation.  
Storage of event log, alarm log and calibration history. Storage of the last 1'500 data records in logger with selectable time interval.

**Safety features**  
No data loss after power failure, all data is saved in non-volatile memory.

## Electrical Connection Scheme

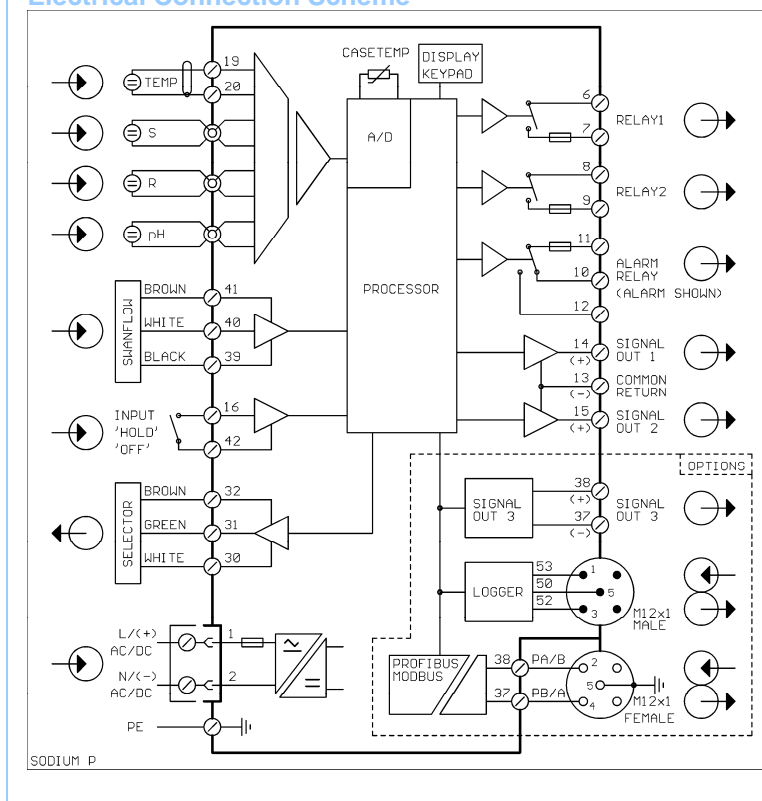

Overvoltage protection of in- and outputs.  
Galvanic separation of measuring inputs and signal outputs.

**Transmitter temperature monitoring**  
with programmable high/low alarm limits.

**1 Alarm relay**  
One potential free contact for summary alarm indication for programmable alarm values and instrument faults.  
Max. load: 1A / 250 VAC

**1 Input**  
One input for potential-free contact.  
Programmable hold or remote off function.

**2 Relay outputs**  
Two potential-free contacts programmable as limit switches for measuring values, controllers or timer for system cleaning with automatic hold function.  
Max. load: 1A / 250 VAC

**2 Signal outputs (3<sup>rd</sup> as option)**  
Two programmable signal outputs for measured values (freely scaleable, linear or bilinear) or as continuous control outputs (control parameters programmable).  
Current loop: 0/4 - 20 mA  
Max. burden: 510 Ω

**Control functions**  
Relays or current outputs programmable for 1 or 2 pulse dosing pumps, solenoid valves or for one motor valve. Programmable P, PI, PID or PD control parameters.

**1 Communication interface (option)**  
RS232 interface for logger download to PC with Microsoft HyperTerminal or RS485 interface (galvanically separated) with Fieldbus protocol Modbus or Profibus DP.

## Analyzer Data

**Sample conditions**  
pH value: ≥ pH 7.0  
Ammonium concentration: < 10 ppm  
Dissolved solids: smaller than 10 ppm  
Flow rate: min. 100 ml/min.  
Inlet pressure: 0.3 - 3 bar (4 - 43 PSI)  
Outlet pressure: ambient pressure  
Temperature: 5 - 45 °C (41 - 113 F)  
No fat or grease.

**Flow cell and connections**  
Made of acrylic glass with photoelectric bubble sensor for sample flow detection.  
One or two (option) sample streams.  
Stream switching time: ≥ 15 min.

Sample inlet: Serto PVDF 6 mm  
Sample outlet: G1/2" adapter for flexible tube Ø 20 x 15 mm

**Panel**  
Dimensions: 850 x (280/400) x 200 mm  
Material: Stainless steel  
Total weight: 12 kg (400 mm panel)