

Complete monitoring system for the automatic, continuous measurement of the acid (cation) conductivity in feedwater, steam and condensate.

**Monitor AMI Powercon Acid**

Complete system mounted on stainless steel mounting panel:

- **Transmitter AMI Powercon** in a rugged aluminum enclosure (IP 66).
- **Swansensor UP-Con1000-SL** 2-electrode conductivity sensor with slot-lock adapter and integrated Pt1000 temperature probe,  $k = 0.04 \text{ cm}^{-1}$ .
- **Flow cell Catcon-Plus-SL** made of stainless steel 316L with flow adjustment valve and digital sample flow meter. Quick sensor release with patented slot-lock design. Integrated, easy exchangeable, transparent cation exchanger vessel with automatic deaeration. Nuclear grade resin with capacity indicator.
- Optional trail vessel with pre-rinse setup for instantaneous resin exchange (lead-and-trail).
- Factory tested, ready for installation and operation.

**Specifications:**

- Conductivity measurement range: 0.055 to 1000  $\mu\text{S/cm}$
- Simultaneous measurement and display of conductivity, sample temperature and flow.
- Temperature compensation preset for strong acids but wide range of others selectable for other sample conditions.
- Big backlit LC display for the reading of all measuring values and operating status.
- Easy user menus with simple programming of all parameters by keypad.
- Electronic record of major process events and calibration data.
- Two current outputs (0/4 - 20 mA) for measured signals (3<sup>rd</sup> as option).

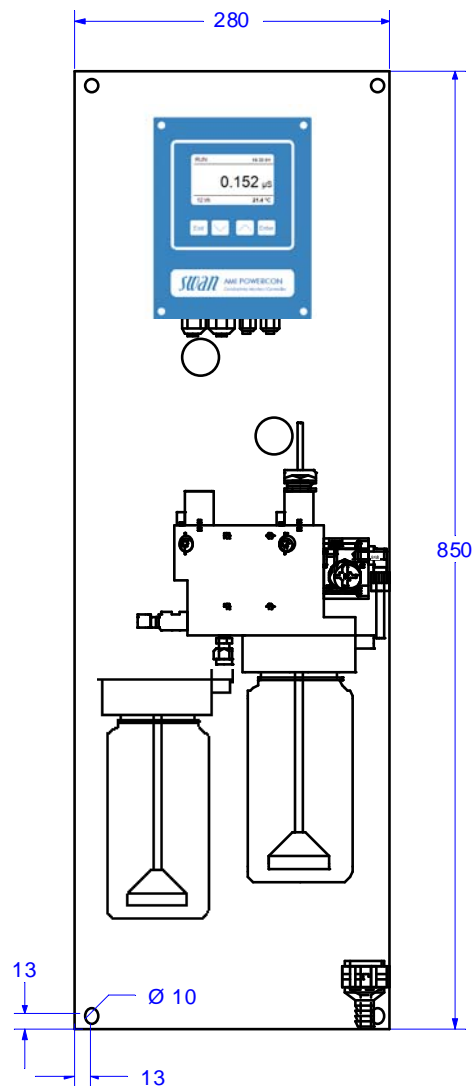

Monitor with optional pre-rinse set-up

Order scheme	Monitor AMI Powercon Acid	A - 2 3 . 4 4 5 .	X	X	X
<b>Power supply</b> .....	100 - 240 VAC / 50/60 Hz .....		1	↑	↑
	24 VDC, direct current .....		2	↑	↑
<b>Signal output option</b> .....	None .....			0	↑
	Third current signal output 0/4 - 20 mA .....			1	↑
	Profibus DP interface .....			2	↑
	HyperTerminal interface (for logger download) .....			3	↑
	Modbus interface (for <i>Webserver</i> connection) .....			4	↑
<b>Pre-rinse option</b> .....	None (but with automatic deaeration).....				1
	Additional cation exchanger vessel with pre-rinse setup .....				2

**Conductivity Measurement**

**Swansensor UP-Con1000-SL** with integrated Pt1000 temperature probe.

<b>Measuring range</b>	<b>Resolution</b>
0.055 to 0.999 $\mu\text{S/cm}$	0.001 $\mu\text{S/cm}$
1.00 to 9.99 $\mu\text{S/cm}$	0.01 $\mu\text{S/cm}$
10.0 to 99.9 $\mu\text{S/cm}$	0.1 $\mu\text{S/cm}$
100 to 1000 $\mu\text{S/cm}$	1 $\mu\text{S/cm}$

Automatic range switching.

**Accuracy:**  
 $\pm 1\%$  of measured value or  $\pm 1$  digit (whichever is greater).

**Temperature compensations**  
Non-linear function (for high purity water), neutral salts, strong acids, strong bases, ammonia, ethanolamine, morpholine, linear coefficient in  $\%/\text{°C}$ , absolute (none).

**Temperature measurement**  
Measuring range: -30 to +130  $\text{°C}$   
Resolution: 0.1  $\text{°C}$

**Sample flow measurement**  
With digital Swan sample flow sensor.

**Transmitter Specifications and Functionality**

Electronics case: Cast aluminum  
Protection degree: IP 66 / NEMA 4X  
Display: backlit LCD, 75 x 45 mm  
Electrical connectors: screw clamps  
Dimensions: 180 x 140 x 70 mm  
Weight: 1.5 kg  
Ambient temperature: -10 to +50  $\text{°C}$   
Humidity: 10 - 90% rel., non condensing

**Power supply**  
Voltage: 100 - 240 VAC ( $\pm 10\%$ ), 50/60 Hz ( $\pm 5\%$ ) or 24 VDC ( $\pm 15\%$ )  
Power consumption: max. 20 VA

**Operation**  
Easy operation based on separate menus for "Messages", "Diagnostics", "Maintenance", "Operation" and "Installation".  
User menus in English, German, French and Spanish.  
Separate menu specific password protection.  
Display of process value, sample flow, alarm status and time during operation.  
Storage of event log, alarm log and calibration history. Storage of the last 1'500 data records in logger with selectable time interval.

**Safety features**  
No data loss after power failure, all data is saved in non-volatile memory.  
Overvoltage protection of in- and outputs.  
Galvanic separation of measuring inputs and signal outputs.

**Electrical Connection Scheme**

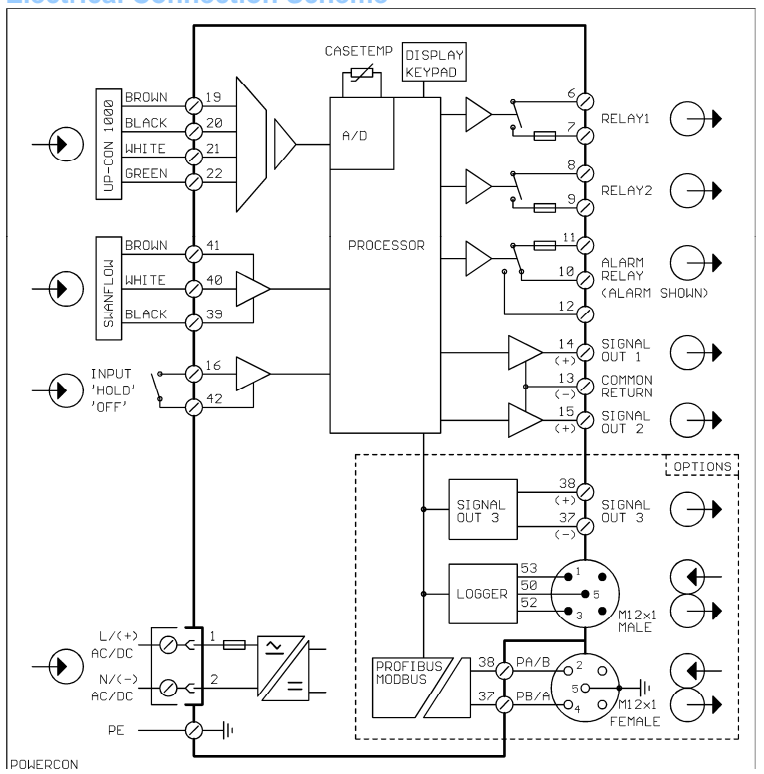

**Transmitter temperature monitoring** with programmable high/low alarm limits.

**1 Alarm relay**  
One potential free contact for summary alarm indication for programmable alarm values and instrument faults.  
Maximum load: 1A / 250 VAC

**1 Input**  
One input for potential-free contact. Programmable hold or remote off function.

**2 Relay outputs**  
Two potential-free contacts programmable as limit switches for measuring values, controllers or timer for system cleaning with automatic hold function.  
Rated load: 1A / 250 VAC

**2 Signal outputs (3<sup>rd</sup> as option)**  
Two programmable signal outputs for measured values (freely scaleable, linear or bilinear) or as continuous control outputs (control parameters programmable).  
Current loop: 0/4 - 20 mA  
Maximum burden: 510  $\Omega$

**Control functions**  
Relays or current outputs programmable for 1 or 2 pulse dosing pumps, solenoid valves or for one motor valve.  
Programmable P, PI, PID or PD control parameters.

**1 Communication interface (option)**  
RS232 interface for logger download to PC with Microsoft HyperTerminal or RS485 interface (galvanically separated) with Fieldbus protocol Modbus or Profibus DP.

**Monitor Data**

**Sample conditions**  
Flow rate: 5 to 20 L/h  
Temperature: up to 50  $\text{°C}$   
Inlet pressure: up to 2 bar  
Outlet pressure: pressure free  
No sand, no oil

**Flow cell and connections**  
Flow cell with flow adjustment valve and digital sample flow meter. Quick sensor release with patented slot-lock design.  
Sample inlet: Swagelok 1/4" tube adapter  
Sample outlet: G 1/2" adapter for flexible tube  $\text{Ø} 20 \times 15$  mm

**Cation exchanger**  
Cleaned resin (1L, nuclear grade) with capacity indicator ready for operation.  
Resin sufficient at 1 mg/L ammonia (pH 9.4). Resin capacity for 1L: 4 months at sample flow 10 L/h, 5 months at 5 L/h.  
Additional trail resin vessel with pre-rinse setup as option.  
Automatic deaeration of resin bottle(s).

**Panel**  
Dimensions: 850 x 280 x 200 mm  
Material: stainless steel  
Total instrument weight: 12.0 kg