

Complete monitoring system for the automatic, continuous measurement of free chlorine, monochloramine, total residual chlorine and combined chlorine in potable water, sanitary water and effluent.

Monitor AMI Codes-II CC

- For the continuous online determination of disinfectants based on the DPD colorimetric method (EN ISO 7393-2; APHA 4500-Cl G).
- Measurement values : free chlorine, monochloramine, total residual chlorine, combined chlorine, flow and if installed pH and temperature.
- Also applicable for water containing additives like cyanuric acid.
- Complete system including measurement and control electronics, photometer, flow indicator, reaction chamber, reagent dosing system and reagent containers.
- Integrated pH measurement with temperature compensation (available as option).
- All usual dosing devices for disinfectants and pH control can be connected either through relays or analog output signals. Two independent controllers can operate simultaneously.
- Dosing of disinfectant can be interrupted automatically with an external signal, e.g. during sample flow interruption or filter backwashing.
- Two (optionally three) selectable measurement values are available as analog output signals.
- Alarm display and activation of alarm relay when user defined, critical limits for a measurement value are reached.
- Continuous, automatic monitoring of main instrument functions (dirty photometer, sample flow, reagents).
- Large back-lit LCD display showing all measured values and status information simultaneously.
- Factory tested, ready for installation and operation.

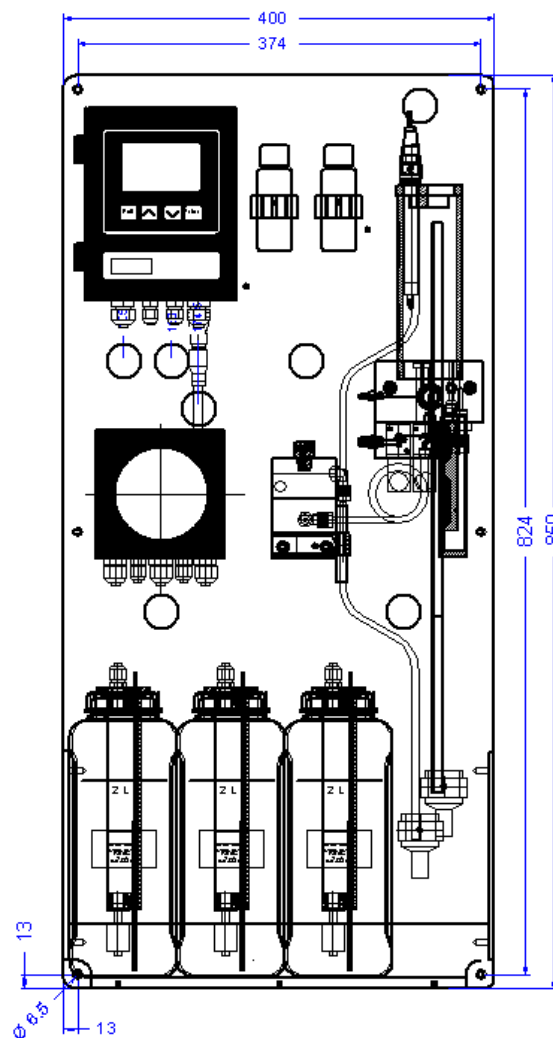

Options:

- pH option containing pH sensor, temperature sensor, cables and electronics board.
- Chemical cleaning module. For details please see separate data sheet no. DenA82312000.

Order scheme	Monitor AMI Codes-II CC	A	2	5	.	4	4	.	7	.	0
Power supply:	100 - 240 VAC, 50/60 Hz								1		
	24 VDC, direct current								2		
pH measurement:	None									0	
	pH- and integrated temperature measurement									1	
Electrical output options:	None										0
	Third current signal output 0/4 - 20 mA										1
	Profibus DP interface										2
	HyperTerminal interface (for logger download										3
	Modbus interface (for Webserver connection.....										4

Disinfectant measurement

Free chlorine, monochloramine, total residual chlorine

Measuring range	Accuracy
0.00 - 1.00 ppm	± 0.01 ppm
1.00 - 3.00 ppm	± 0.06 ppm
3.00 - 5.00 ppm	± 0.2 ppm

Combined chlorine: calculated by the difference of total residual chlorine and free chlorine.

Measurement time:	2 min.
Cycle time free chlorine:	1 - 12 min.
Cycle time total resid. chlorine:	6 - 60 min.

pH measurement (option)

Measuring range:	pH 2 - 12
Resolution:	0.01 pH

Temperature measurement (Option)

with Nt5k sensor	
Measuring range :	-30 to +100 °C
Resolution :	0.1 °C

Transmitter Specifications and Functionality

Electronics case:	Aluminum
Protection degree:	IP 66 / NEMA 4X
Display:	backlit LCD, 75 x 45 mm
Electrical connectors:	screw clamps
Ambient temperature:	-10 to +50 °C
Limit range of operation:	-25 to +65 °C
Storage and transport:	-30 to +85 °C
Humidity:	10 to 90 % relative, non condensing

Power supply

Voltage:	100 - 240 VAC (± 10 %), 50/60 Hz (± 5 %) or 24 VDC (± 15 %)
Power consumption:	max. 20 VA

Operation

Easy operation based on separate menus for "Messages", "Diagnostics", "Maintenance", "Operation" and "Installation". User menus in English, German, French and Spanish
Separate, menu specific password protection.
Display of process value, alarm status and time during operation.
Storage of event log, and alarm log and calibration history.
Storage of the last 1'500 data records in logger with selectable time interval.

Safety features

No data loss after power failure, all data is saved in non-volatile memory. Over-voltage protection of in- and outputs. Galvanic separation of measuring inputs and signal outputs.

Transmitter temperature monitoring

With programmable high/low alarm limits.

Electrical Connection Scheme

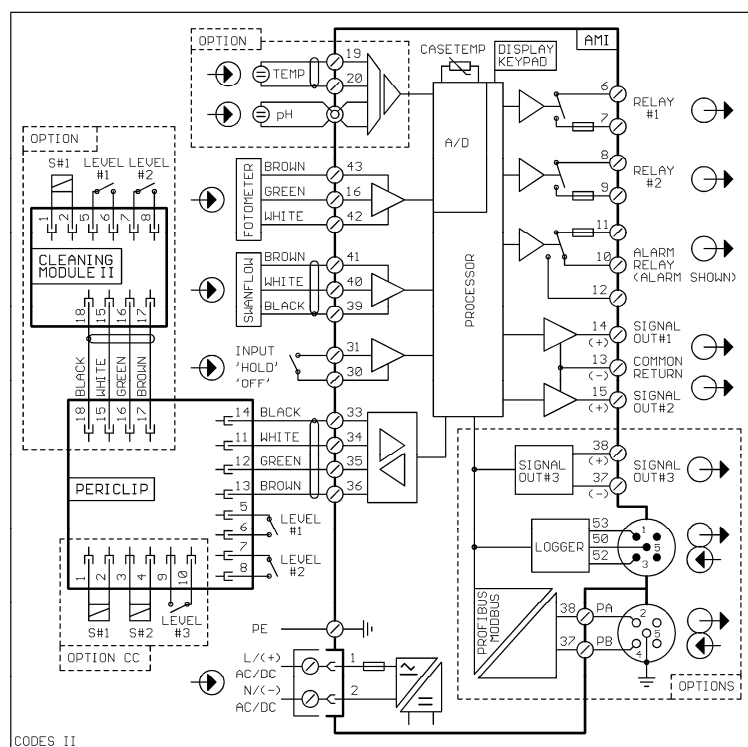

Real-time clock with calendar

For action time stamp and preprogrammed actions.

1 Alarm relay

One potential free contact for summary alarm indication for programmable alarm values and instrument faults. Maximum load: 1A / 250 VAC

1 Input

One input for potential-free contact. Programmable hold or remote off function.

2 Relay outputs

Two potential-free contacts programmable as limit switches for measuring values, controllers or timer with automatic hold function. Rated load: 1A / 250 VAC

2 Signal outputs (3rd optional)

Two programmable signal outputs for measured values (freely scaleable, linear or bilinear) or as continuous control outputs (control parameters programmable). Current loop: 0/4 - 20 mA
Maximum burden: 510 Ω

Control functions

Relays or current outputs programmable for 1 or 2 pulse dosing pumps, solenoid valves or for one motor valve. Programmable P, PI, PID or PD control parameters.

1 Communication interface (option)

RS232 interface for logger download to PC with Microsoft HyperTerminal or RS485 interface (galvanically separated) with Fieldbus protocol Modbus or Profibus DP.

Remote instrument access with PC requires Modbus interface and optional Webserver.

Monitor Data

Sample conditions

Water consumption:	min. 10 l/h
Water inlet pressure	0.15 to 2 bar
Sample temperature:	5 to 50 °C

Flow cell and connections

Made of acrylic glass with water inlet filter and needle valve.
Openings for pH and temperature sensors.
Inlet tubing: 6 x 8 mm
Outlet pressure: atmospheric drain
Outlet tubing: 15 x 20 mm (1/2")

Panel

Panel dimensions:	400 x 850 x 200 mm
Panel material:	PVC
Weight:	9.0 kg